

CertainTeed

MATTERHORN[®]

METAL ROOFING

Shake / Slate Installation Guide

ASK ABOUT ALL OF OUR OTHER CERTAINTEED[®] PRODUCTS AND SYSTEMS:

ROOFING • SIDING • TRIM • DECKING • RAILING • FENCE
GYPSUM • CEILINGS • INSULATION

www.certainteed.com <http://blog.certainteed.com>

CertainTeed Corporation
20 Moores Road
Malvern, PA 19355

Professional: 800-233-8990
Consumer: 800-782-8777

© 2016 CertainTeed Corporation, Printed in the U.S.A.
Code No. 20-20-3624



Table of Contents

System Components.....	2
General Conditions, Safety and Roof Preparations.....	3
Screw and Fastening Specifications	4
Eave/Drip Edge.....	5
Inner Gable	6
Outer Gable	7
Open Valley Method.....	8
Closed Valley Method	9
Valley Detail	10
Valley Cap Detail.....	11
Panel Layout and Installation.....	12
Sidewall With Siding Option 1	17
Sidewall With Siding Option 2.....	18
Endwall Option 1 & 2	19
Vents, Pipes and Skylights.....	20
Brick Sidewall/Chimney Option 1	21
Brick Sidewall/Chimney Option 2	22
Transition Detail Option 1.....	23
Transition Detail Option 2.....	24
Roof Jack Assembly.....	25
Vented Ridge Cap.....	26
Non-Vented Ridge Cap	27
Tools and Accessories	28



Watch detailed Matterhorn® Shake and Slate installation videos
online at certainteed.com

System Components

- A. Shake Panel
- A. Slate Panel
- B. 1.5" EL T-Style
- C. Ridge Cap
- D. CertainTeed Ridge Vent
- E. Inner Gable Shake/Slate
- F. Outer Gable
- G. Side Wall Flashing
- H. End Wall Trim
- I. Valley Closure Shake/Slate
- J. 3" Valley Closure Cap
- K. .016 x 24" WL W-Valley
- L. Weep Trim
- M. Valley Cleat

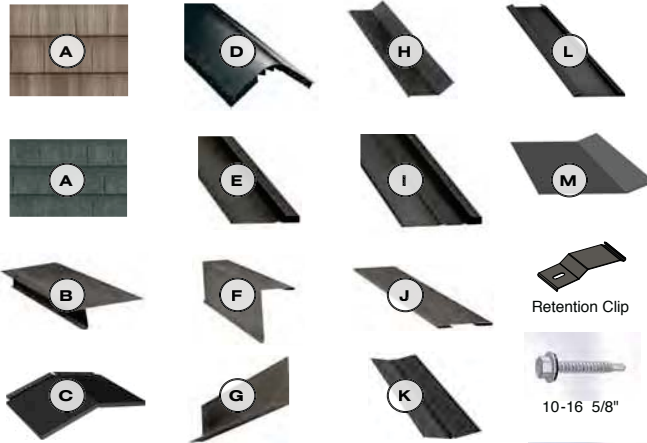

Retention Clip

10-16 5/8"

10-16 1-1/4"

10-12 2"

10-12 3"

All screws used while installing Matterhorn® Slate or Shake must be of a recommended screw type. Screws must be long enough to penetrate the roof deck. Refer to diagram on page 4.

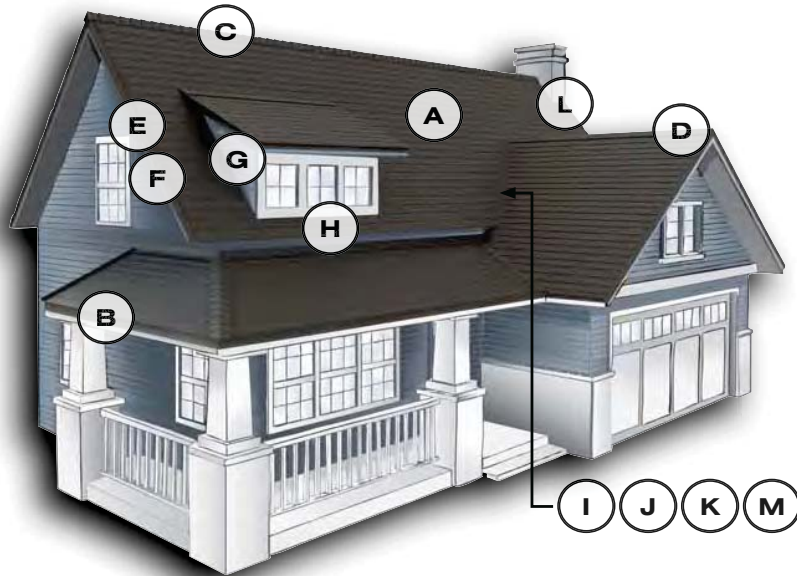

This page only refers to the area that components are placed for the Matterhorn Metal Roofing System. Refer to the bid sheet at the end of the manual for actual components sizes and detailed information.

General Conditions, Safety and Roof Preparations

General Installation Guidelines

- CertainTeed recommends tearing off existing roof systems and installing Matterhorn® Metal Roofing over a clean deck.
- Matterhorn Metal Roofing must be installed on a solid roof deck. The roof deck must be 15/32" to 1/2" thick plywood, or 7/16" thick non-veneer or nominal 1" thick wood deck.
- DiamondDeck® synthetic underlayment and MetaLayment/WinterGuard® HT high temperature self-adhering underlayment must be installed prior to the installation of the metal roofing products—refer to local building code.
- MetaLayment/WinterGuard HT is required in all valleys and eaves.
- Slope requirements:
 - 3/12 — 4/12 slope: MetaLayment/WinterGuard HT must be used over the entire roof deck.
 - < 3/12 slope: Do not install Matterhorn Metal Roofing.
- Valleys, as well as eave/drip edge, rake, endwall and sidewall flashing must be installed before the panels.
- When cutting panels to length, begin cutting from the top of the panel, cutting downwards towards the preformed bend at the bottom. This ensures the cleanest shear and keeps the rolled edge intact for optimal locking.
- Always install Matterhorn Slate and Shake panels from right to left, then bottom to top, beginning with the bottom right corner of the roof deck.
- Foot traffic: Minimize foot traffic. Wear clean, soft sole, non-marking shoes when walking on installed panels.
- Upon completion of the installation, inspect the roof surface for metal shavings or other loose material. Remove by wiping softly with a cloth, being careful not to scratch the painted surface. Remove dirt with a damp rag.

Fastening

- Fasten all panels to the roof using only the required screw type, inserting one into each of the holes along the top of the panel. For high wind areas three additional screws must be installed (see page 6). Ensure each panel is fully engaged to the one below via the pre-rolled feature at the bottom of the panel before fastening it to the roof deck.
- Overlap clips must be installed on every panel.

Product Handling

- General Handling: Carry the roofing panels standing on their edge, instead of laying flat, to keep them from bending and warping.
- Walking along panels: Wear clean, soft-sole, non-marking shoes when walking on installed roof panels. Step only on areas that have full contact to the roof deck.

Safety Guidelines

Follow all governmental safety procedures, including, but not limited to, all OSHA guidelines. Always wear safety gloves, safety glasses and fall protection gear when installing Matterhorn Metal Roofing.

Roof Preparations:

Prior to installing the synthetic and self-adhering underlayments, clear the roof of any debris or protrusions that could puncture or damage the protective membrane. Installing roofing panels on uneven surfaces will cause deflection or distortion in the metal surface. (Note: Surface wave in the material is not a cause for rejection of the product.)

Ventilation

Proper ventilation must be achieved to avoid moisture and heat buildup in the attic space, or between the layers of the building envelope. Consult local building code for NFA (Net Free Area) rating requirements.

- **Intake vs. exhaust:** To achieve maximum airflow through the attic, the amount of intake at the eave must be less than or equal to the exhaust at the ridge.
- **Soffit vents** are found on the underside of the eave overhang. This is the primary source for the intake of air to the attic.
- **Ridge vents** are located at the peak of the roof and are the primary exhaust outlet for accumulated hot, moist air.

Class A Fire Rating

Matterhorn tested using Georgia-Pacific 1/4" DensDeck. For a Class A fire rating, use Georgia-Pacific 1/4" DensDeck. A Class A fire rating is not applicable if Matterhorn Metal Roofing panels are installed over existing 3-tab shingles.

Screw and Fastening Specifications

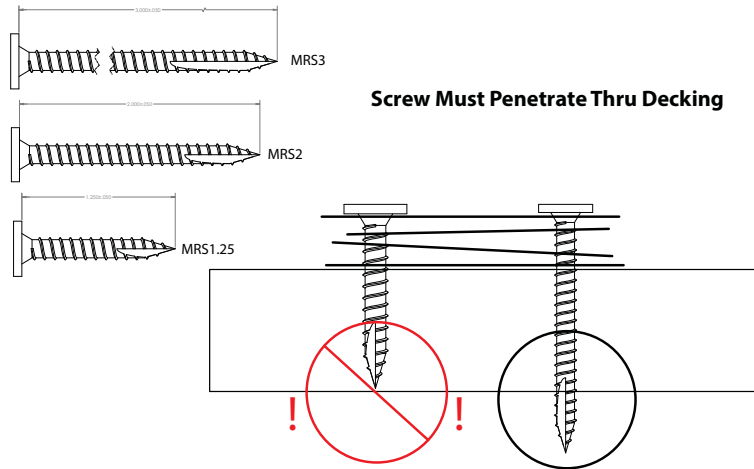

Standard

Standard 4 Screw Installation Using Pre Punched Holes.

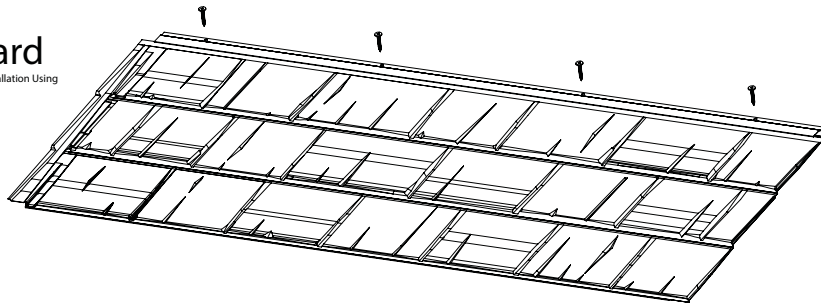

High Wind Areas

High Wind Area 7 Screw Installation. Add 3 More Screws Centered Between the Pre Punched Holes for 130 MPH Rating.

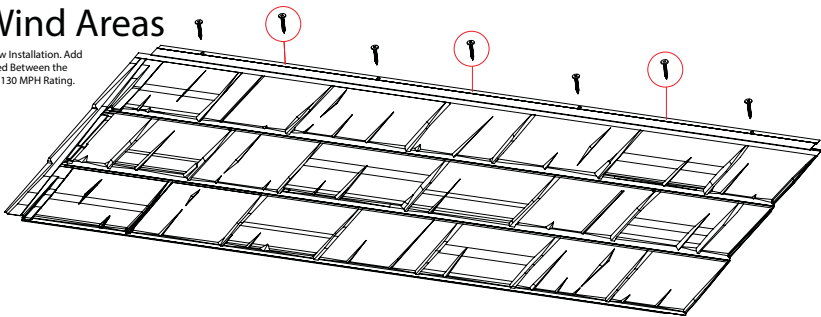

4

Watch detailed Matterhorn® Shake and Slate installation videos online at certainteed.com

Eave/Drip Edge

Eave Edge Detail:

1. Fasten drip edge to the roof deck every 12" with panhead screws.
2. Ensure that drip edge is installed securely, the drip edge is designed to hold down the bottom of the first row of panels.
3. When installing, ensure that drip edge is straight and square to the roof plane and does not follow any wave in the fascia. This may require a chalk line.
4. Matterhorn® drip edge is designed to be installed on up to a 12/12 pitch without modification. On steeper roof pitches, drip edge can be bent in a siding brake for easier installation. By bending forward the leg of the drip edge it will fit tight on a steep slope roof.

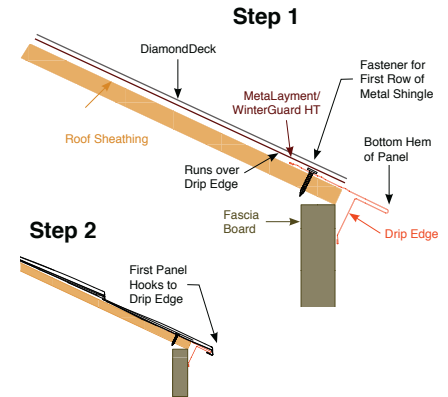

1. Cut and bend drip edge trim on the outside to conform to rake edge and inner and outer gable.



2. When adjoining sections of drip edge, cut the front nose on an angle to allow for a tight overlap and a good fit.



3. Sometimes the bottom hem will also need to be cut to make sure there is a tight fit. Screws should be in the middle of the width halfway up the roof.



4. After the drip edge is completely installed on eaves, install MetaLaym/WinterGuard® HT over the drip edge in accordance with local building codes, followed by DiamondDeck®.

5

Watch detailed Matterhorn® Shake and Slate installation videos online at certainteed.com

Inner Gable

Inner Gable Detail 1:

1. Install the inner gable up the rake edges using panhead screws every 12". The opening of the inner gable should face toward the roof deck. The back side should align with the outside edge of the roof deck.
2. Overlap inner gable trim as per the sequence below. Overlap by at least 6".
3. In high wind areas check your local code requirements for approved installation techniques.

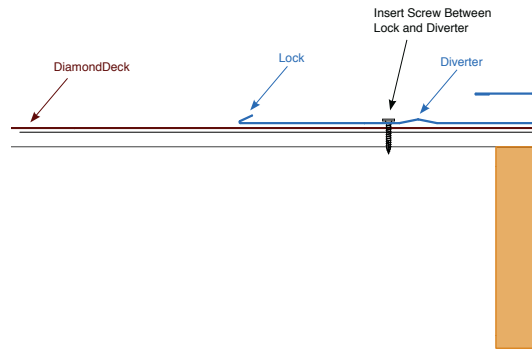

Cut bottom of inner gable so outside weeping channel will protrude past drip edge ¼".



Cut out top leg of inner gable trim to allow for tight, waterproof overlapping.



When overlapping, apply sealant under overlap. Be sure to screw every 12" between the diverter and the water lock.



Install inner gable as a whole piece. When adding a second inner gable trim, open up the water lock and cut out the top section to allow for tight, overlapping, waterproof fit.

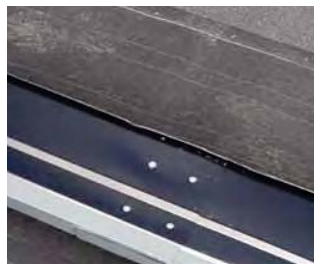

Refit the overlapping water locks together with a hand seamer.

Outer Gable

Outer Gable Detail 1:

1. Install the outer gable over the inner gable. This may require opening the hem slightly.
2. Make sure the outer gable fits parallel with the inner gable and the lap joint is staggered with the inner gable lap joint.
3. Outer gable should be hemmed to inner gable and fastened with painted 5/8" hex head screw.

Note: For high-wind areas additional fasteners may be needed into the fascia. Consult local codes to determine if your area is a high wind area.



Open up the hem on the outer gable with your fingertips to allow easy placement.

Outer Gable, Step 1

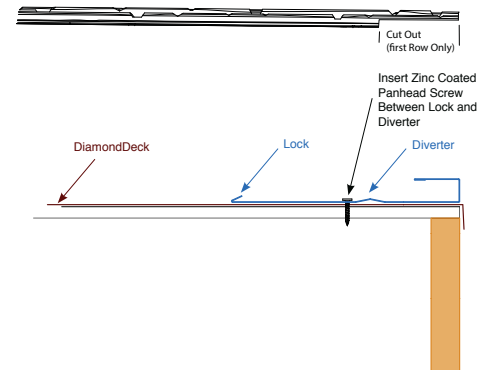

Outer Gable, Step 2

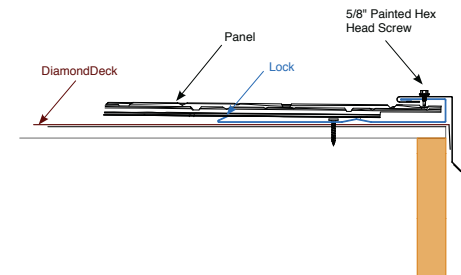

Open Valley Method

Open Valley Method:

1. Be sure to run MetaLayment/WinterGuard HT® in all the roof valleys.
2. Install the w-valley at the bottom of every roof valley overhanging the drip edge. Lap the next 10' piece over the first one at least 6". The water lock will have to be opened up on the top to allow the next section to nest inside. Two rows of sealant are required in the overlap.
3. Tack the valley metal in place with panhead screws 1" down from the water lock. Push the metal down into the roof profile before fastening to prevent bridging or spanning of the metal between the two roof slopes.
4. The valley cleat is installed on top of the w-valley, fastening every 12". Before fastening, apply bead or tape sealant between the cleat and valley. Use the ribs in the valley to align the cleat parallel to the center rib at the desired width.
5. Angle cut the roof panel leaving 1" of extra metal to be folded under the cleat. "V" cut the course breaks and remove the nail flange to leave "tabs" to be bent under the cleat.
6. Hook the cut and bent tabs of the panel on the valley cleat before fastening through the nail holes along the top of the panel.

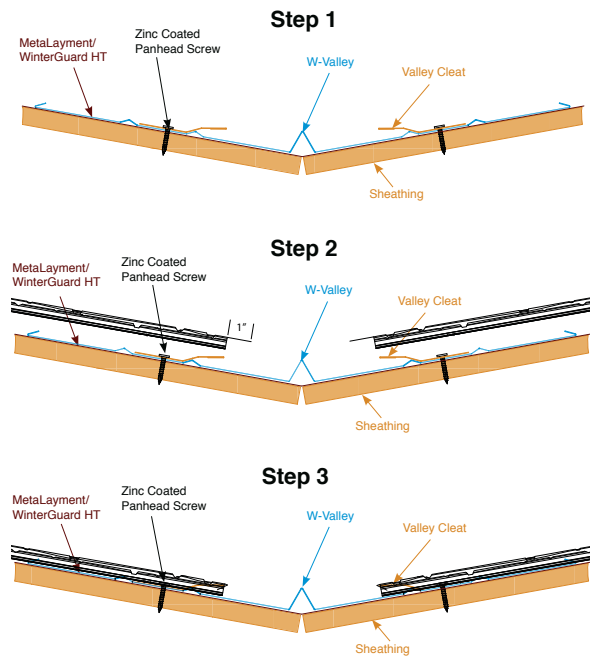

8

Watch detailed Matterhorn® Shake and Slate installation videos online at certainteed.com

Closed Valley Method

Closed Valley Method:

1. Install the valley closures using panhead screws every 12" between the diverter as shown in diagram from the second water diversion rib.
2. Be sure the panel is cut to fit the valley angle. For valleys longer than 10', overlap the sections at least 6", with butyl sealant between the layers of metal. Cut the top off the valley closure and open up the water lock. This will allow the upper valley closure to fit inside the lower valley closure.

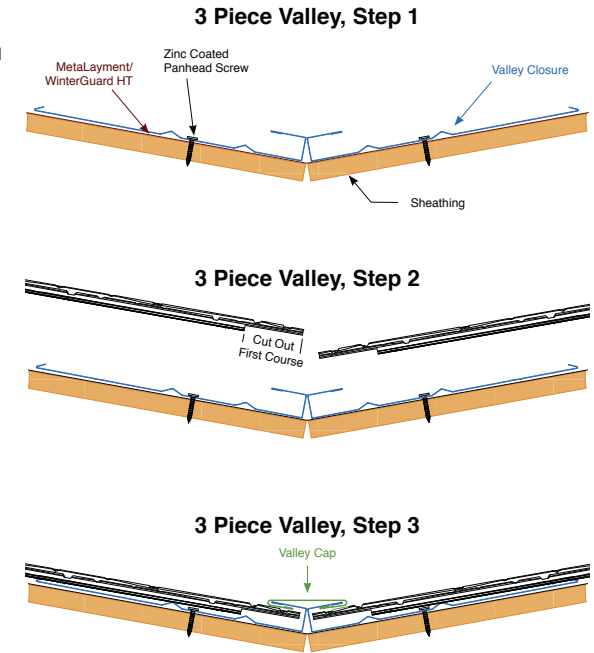

1. Install Valley Closure Trim in the manner illustrated and shown above.

2. When overlapping, apply sealant under overlap. Be sure to screw every 12", between the diverter as shown in above diagram.

3. Cut roofing panel to match angle of Valley Closure Trim.

9

Watch detailed Matterhorn® Shake and Slate installation videos online at certainteed.com

Valley Detail



1. Install valley closure, lining up the inner diverter with the drip edge. Attach closure with screws between the two diverters.



2. Cut the bottom hem of the first panel at the bottom of the valley closure. This will allow the valley closure to overhang the drip edge.



3. Cut the roof panels at the angle of the valley, fitting it as close to the inside of the valley closure as possible. Extra fasteners may be needed to secure the panels in the valley.



4. At the top of the valley apply sealant and install valley closure to be water tight. Apply sealant neatly and completely along all sides of the valley trim.



5. Both sides of the valley closure need to be water tight.



6. On a gable protrusion, when installing panels into valley, take frequent measurements to ensure that the first course above the valley peak will be aligned horizontally.



At the bottom of all trim pieces, allow for weeping of water. Panels will need to be notched out to allow water to escape.

Valley Cap Detail



1. Install the Valley Cap by sliding it down from the top or up from the bottom. Hem to valley or secure with painted screws as necessary.

Make sure the joints in the valley cap are staggered from the joints in the valley closure.

Overlap sections of the valley cap by approximately 1" to keep water from entering between valley closures.

For long valley or where cap becomes difficult to slide over the valley, open up the hems on the valley cap and attach from the side. Then re-hem the valley cap using a hand seamer.

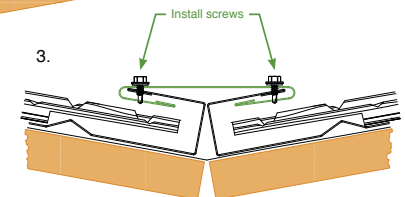
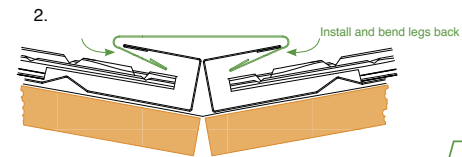
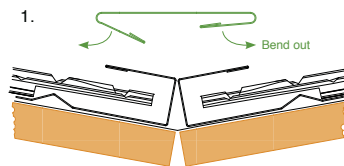
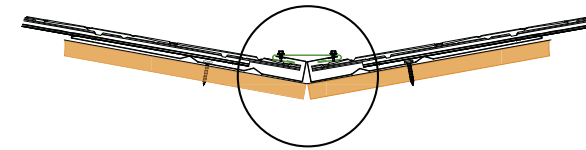
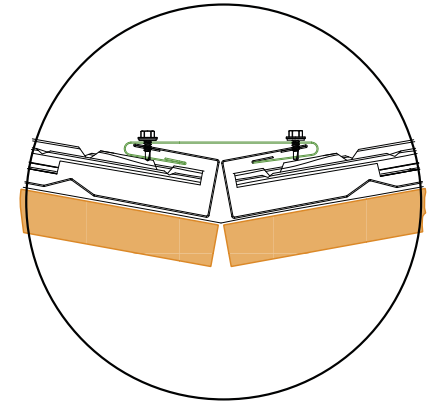

Panel Layout and Installation



When starting rows of panels, ensure that the drip edge is straight and true. You can do this by snapping a chalk line.

When installing panels, it is best to install in pairs. Install screw at a 90° angle. Do not stand on unsecured panel. Ensure that panel is locked in at the bottom and sidelap is aligned properly.

Clip is used between the vertical overlap to keep seam closed. It will also eliminate panel uplift in extreme weather. Ensure clip is engaged while installing screws.

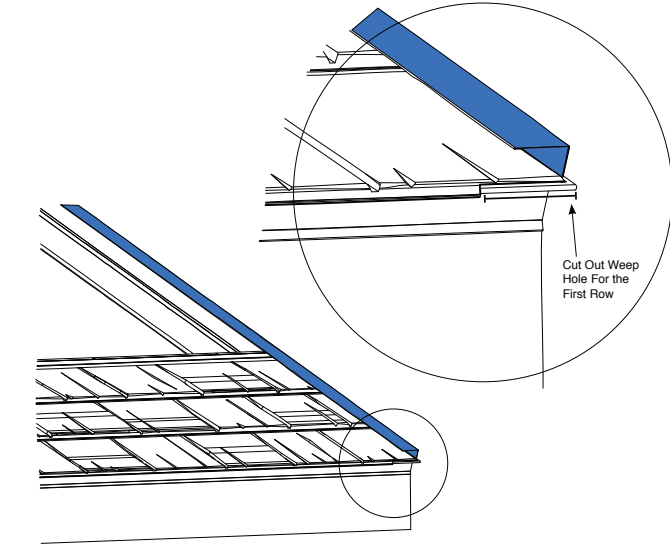

Clip placement on panel. The clip rests inside a recessed indent/pocket.

Panel Layout and Installation

Slate Panels

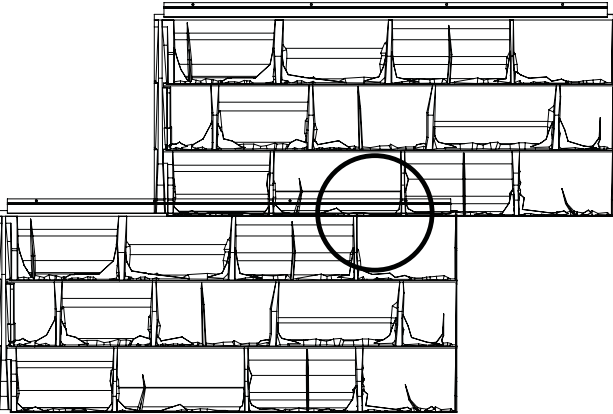
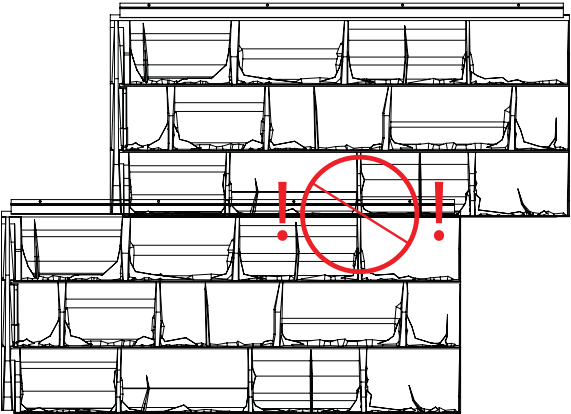

Shake Panels

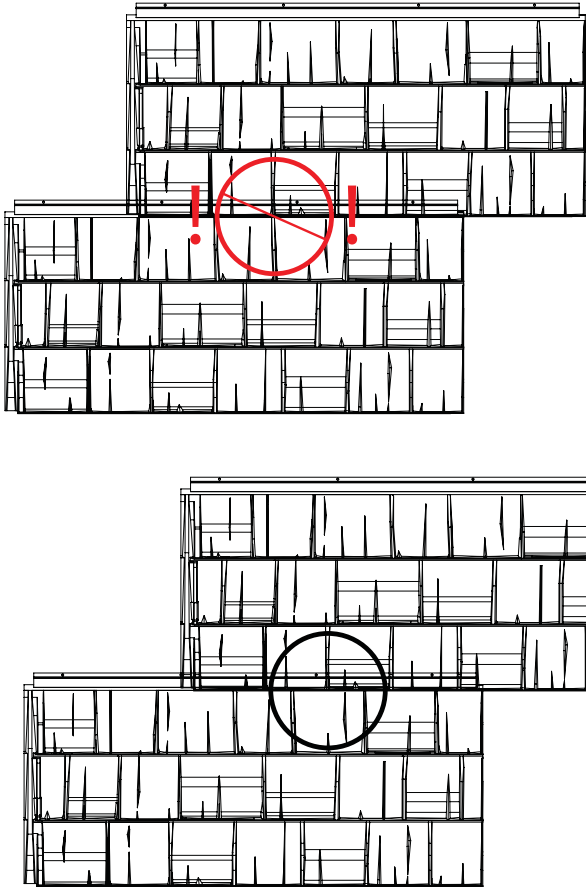

Shake Only

Stock edge of panel should just cover the mounting hole, or centered between the holes.

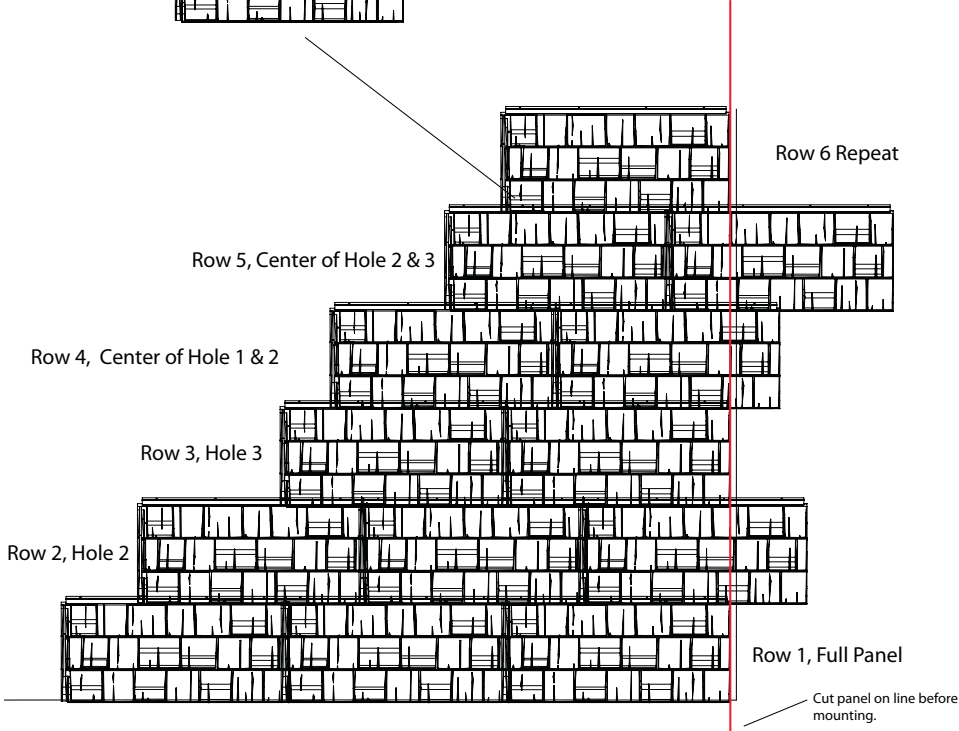
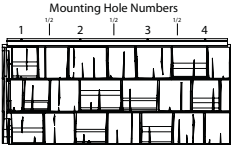

Panel Layout and Installation: Slate Only

Slate Only

Stock edge of panel should just cover the mounting hole, or 4" to the right of holes 1 & 2.

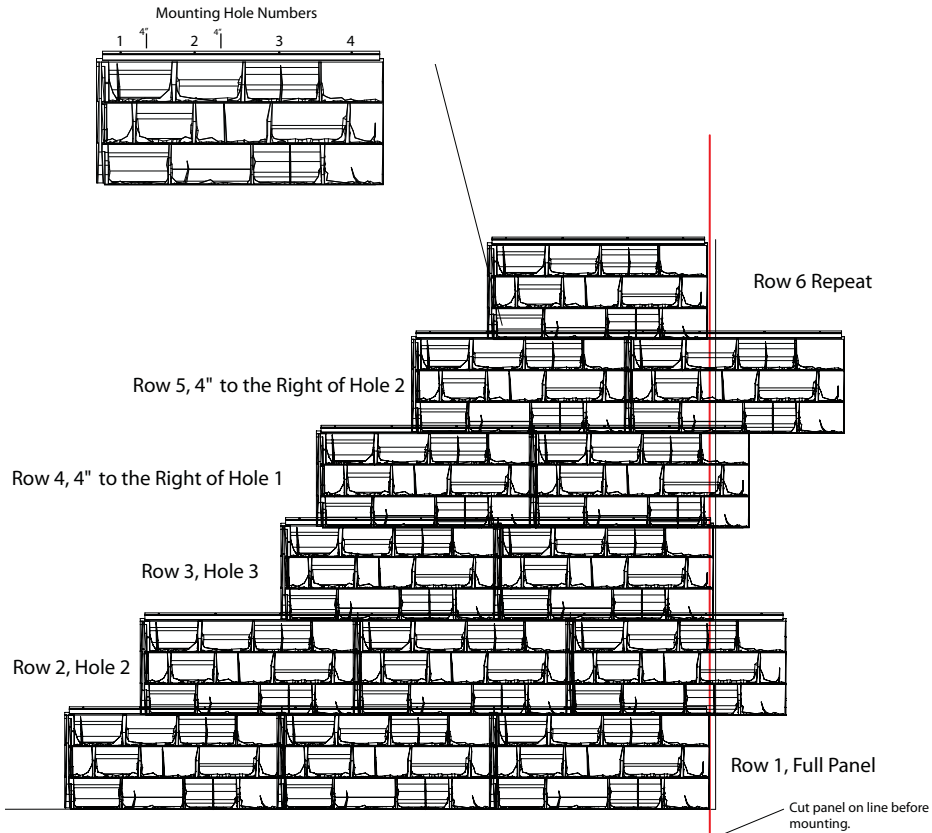

Sidewall With Siding Option 1



Option 1

1. Apply MetaLayment/WinterGuard® HT.
2. Install inner gable before the panel, fastening every 12", between the water lock and the diverter.
3. Install the sidewall flashing over both the panel and the inner gable, hooking the bottom hem of the sidewall flashing over inner gable. Seal and fasten sidewall flashing into the sidewall.
4. Cut panel to the length needed to meet the sidewall inside the inner gable.
5. Install the panel with the cut side inside the inner gable.

Sidewall Option 1 Detail

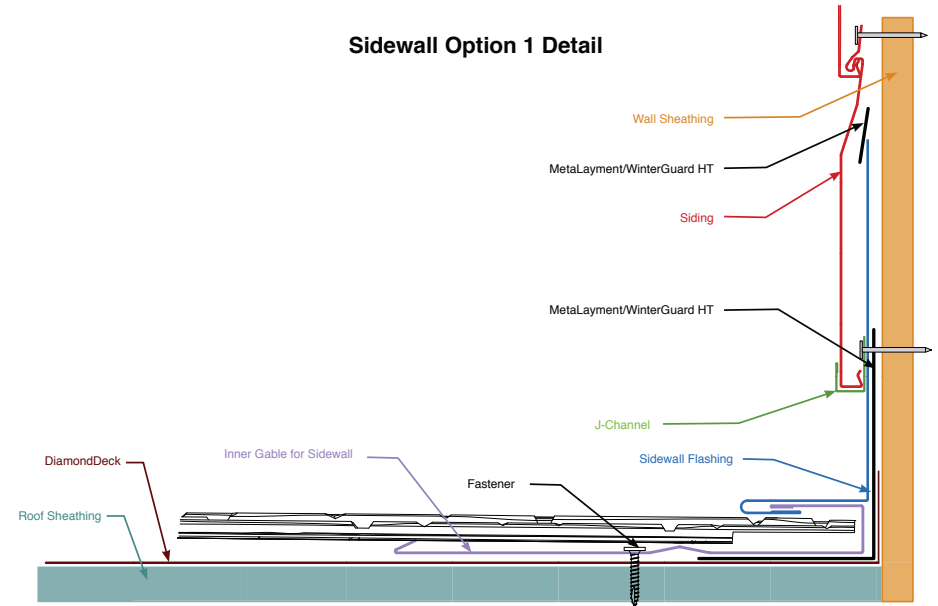

Sidewall With Siding Option 2

Option 2 (Applies to masonry/stucco)

1. Add MetaLayment/WinterGuard® HT from sidewall to roofing deck on top of the DiamondDeck.
2. Bend the metal panel up the wall a minimum of 4"-6" or work with your flashing size.
3. Add MetaLayment/WinterGuard HT to bent area of panel when needed.
4. Bend matching steel roofing coil into counter flashing shape and install.
5. Place beads of sealant per standard counter flashing installation.



Sidewall Option 2 Detail

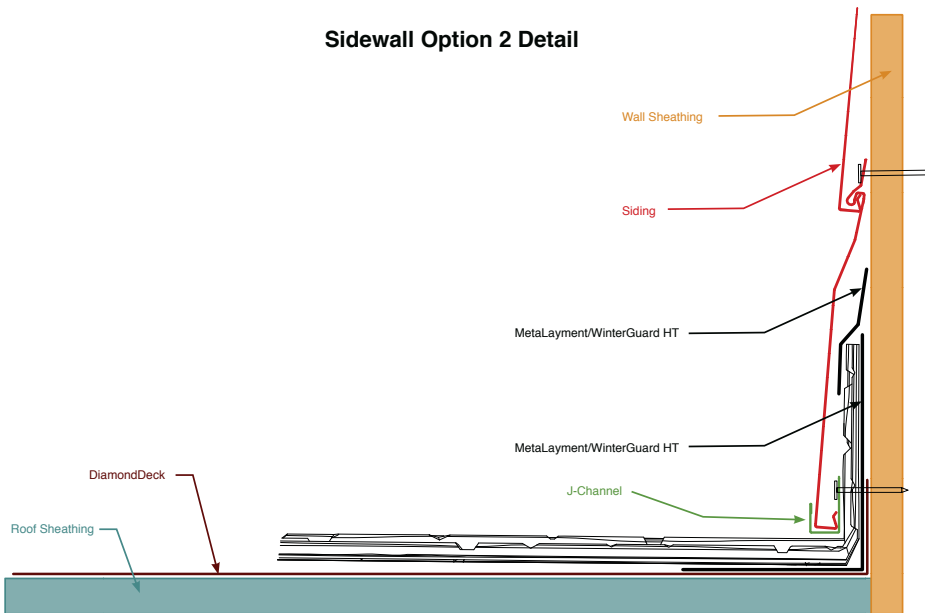

18

Watch detailed Matterhorn® Shake and Slate installation videos online at certainteed.com

Endwall Option 1 & 2

Endwall Option 1

1. Bend the top of a metal panel up the end wall.
2. Install MetaLayment/WinterGuard® HT or sealant along bend if the kinked metal creates a hole.
3. Attach endwall flashing under siding and over the bent panel.
4. Fasten endwall flashing to wall, ensuring the hemmed end covers the panel below appropriately.

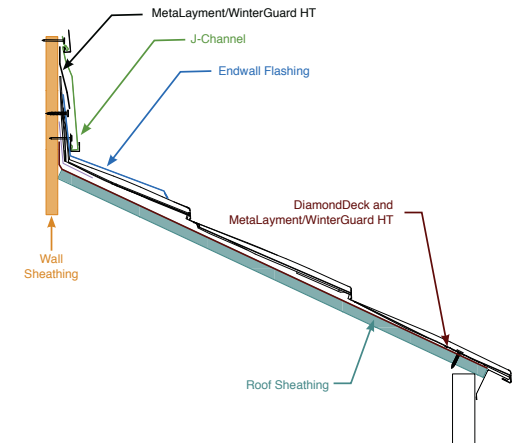

Endwall Option 2

1. Install inner gable.
2. Install sidewall flashing onto inner gable. Bend sidewall flashing to appropriate angle.

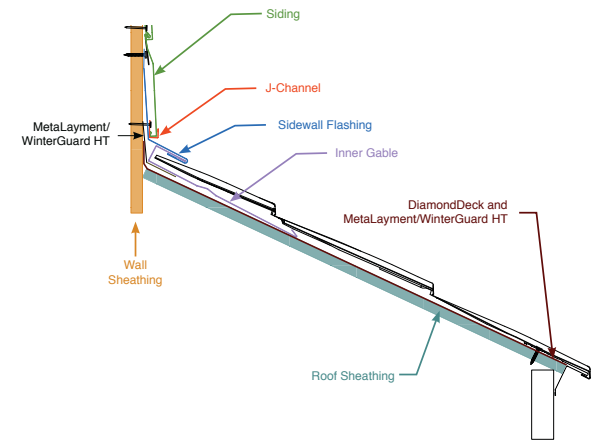

19

Watch detailed Matterhorn® Shake and Slate installation videos online at certainteed.com

Vents, Pipes and Skylights

Vents and Pipes:

Install MetaLayment/WinterGuard® HT or sealant over top of the DiamondDeck® to create under seal at the pipe. Cut panels tightly against pipe and apply sealant to ensure the panel is water tight to the pipe. Install high quality EPDM/silicone pipe boots per manufacturer's instruction.

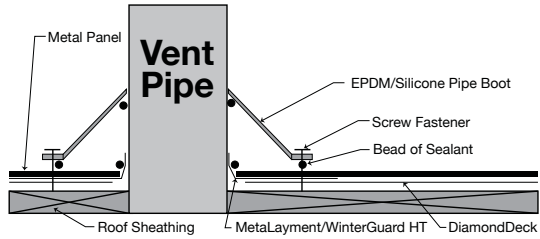

Skylights:

Install MetaLayment/WinterGuard HT sealing the skylight frame to the DiamondDeck. Cut and bend roof panels up the edge of the skylight frame. Make sure the cut edge of the panel is under lip of the flashing cap. Weep trim may be installed under the bend of the panel for better protection.

**Note: Install skylights according to manufacturers instructions.*

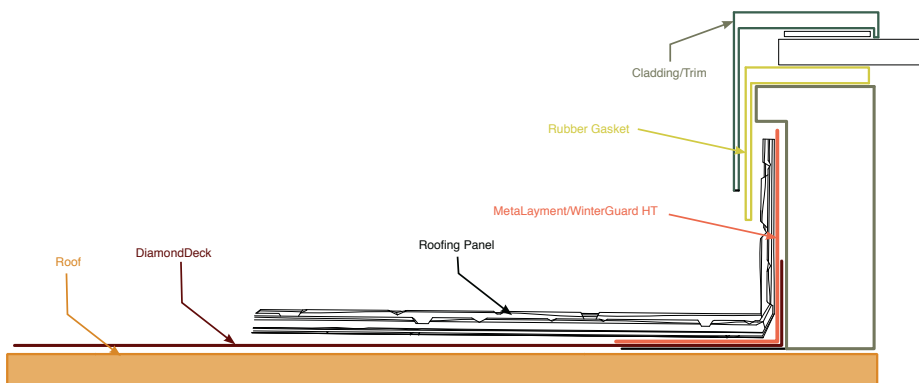

Brick Sidewall/Chimney Option 1

Brick Sidewall/Chimney Option 1:

Install inner gable before the panel is set. Install sidewall flashing per standard installation, apply MetaLayment/WinterGuard® HT if needed for extra protection. Place beads of sealant on the sidewall flashing, bend steel trim coil into appropriate counter flashing shape and install. The metal panels may now be cut and installed.

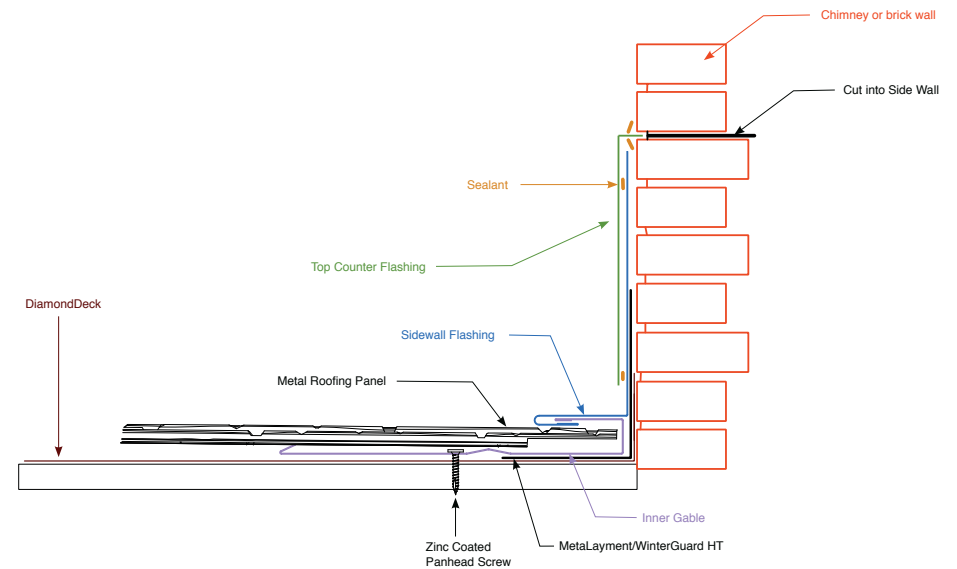

Brick Sidewall/Chimney Option 2

Chimney Option 2:

Cut metal panels to shape of chimney and bend up along the wall approximately 4"-6". Place MetaLayment/WinterGuard® HT and sealant over the bent panels. Cut and bend metal roofing coil to size in order to make a correctly shaped counter flashing. Install counter flashing securely along the cut into the side of the chimney.

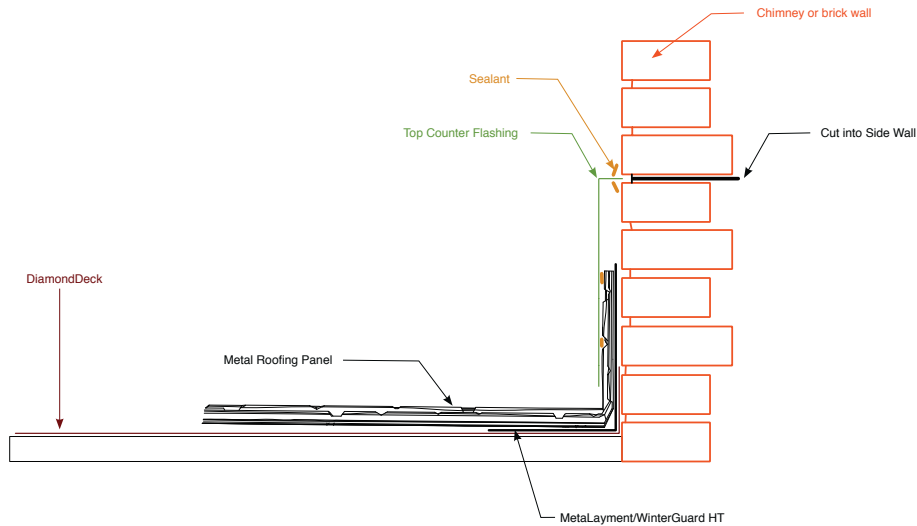

Transition Detail Option 1

Transition Detail

During panel installation, the roof plane may change pitch.

1. For inside transitions, panels can be bent in a field brake. Measure from the bottom of the panel to the roof transition. Mark panel. Bend panel on mark. Install over transition.
2. For outside transitions, panels can be bent in a field brake. Measure from the bottom of the panel to the roof transition. Mark panel. Bend panel on mark. Remove fastening flange. Install over transition. Securing in 4 places.
3. Install drip edge parallel to the transition, and directly over bend in panel. Continue up the roof installing panel over drip edge.



Transition Detail Option 2

Transition Detail

During panel installation, the roof plane may change pitch at a point that will require endwall flashing.

1. Be sure to fasten panel securely to roof deck and in a water tight manner.
2. Apply sealant over lower panel and under the transition flashing.
3. The transition trim (end wall flashing) will need to be secured with water tight fasteners to the lower panels and secured to the deck above to allow connection to the next row of panels.
4. Install a valley cleat just above the bend.
5. If the next course is a short course, cut and hem panel in the desired location so the upper course align.

Transition Detail Option 2, Step 1

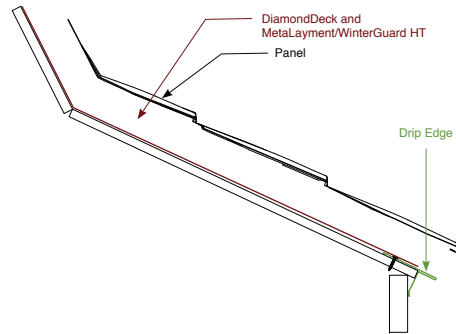

Transition Detail Option 2, Step 2

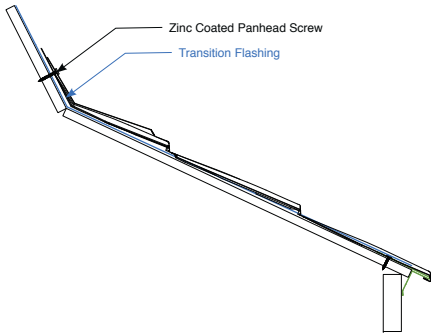

Transition Detail Option 2, Step 3

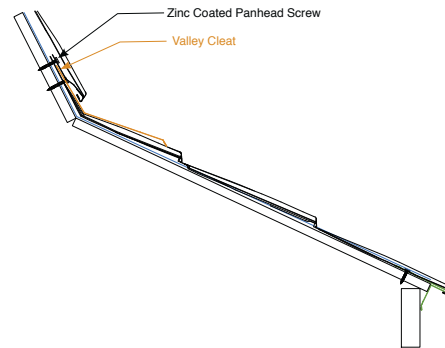

24

Watch detailed Matterhorn® Shake and Slate installation videos online at certainteed.com

Roof Jack Assembly



1. Cut and install wood shims behind panel to support roof jack and stop panel from denting.



2. Wrap roof jack components that come in contact with panel tape to prevent scratching. Be sure to install jack into structural support.

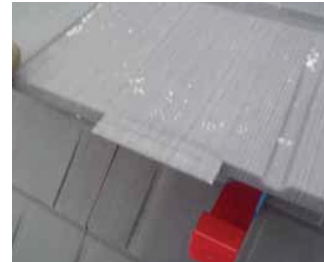

3. Cut and bend out bottom hem of next panel course so panel can be installed over roof jack.



4. After panel is installed, roof jack is ready to be used. Be sure to comply with safety regulations.



5. When finished, remove roof jack safely.



6. After roof jack is removed, apply sealant under flap.



7. After sealant is applied, use a wooden tool to close and tuck flap in. Done correctly, it will be very unnoticeable from the ground.

25

Watch detailed Matterhorn® Shake and Slate installation videos online at certainteed.com

Vented Ridge Cap

Vented Ridge Cap: Using CertainTeed Ridge Vent

1. Cut 2" slot into the roof deck, then cover with DiamondDeck®. Leave DiamondDeck uncut until ridge vent is ready to be installed.
2. The last row of panels needs to be cut to the opening in the roof deck without blocking the airflow. Cut DiamondDeck to allow for proper ventilation.
3. Install CertainTeed Ridge Vents over metal panels with 3" screws to roof deck.
4. Install vent fasteners in areas required according to product specifications.
5. Install ridge cap with same fasteners used to install the vent system.



When starting ridge cap installation, bend first cap down over outer gable trim and fasten securely.

CertainTeed ridge cap is designed with multiple pre-punched holes for fastening. This allows the installer to place the fasteners in the optimum position; in nail line.

The design of the CertainTeed ridge cap allows for the best water tight connection. Ridge cap can be installed in any direction, and is not limited to prevailing weather.

Ridge Cap Detail

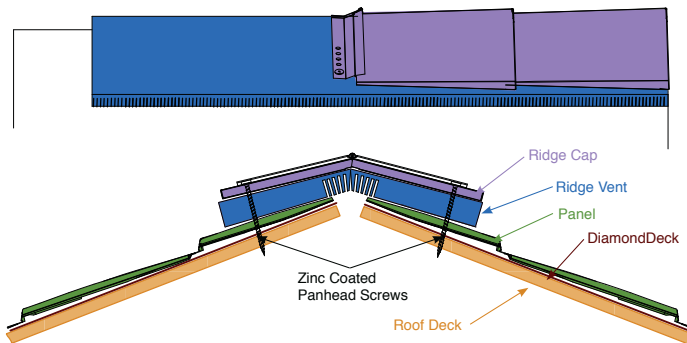

26

Watch detailed Matterhorn® Shake and Slate installation videos online at certainteed.com

Non-Vented Ridge Cap

Non-Vented Ridge of Hip Cap

1. The DiamondDeck® is left uncut when venting is not needed.
2. With a spray foam insulated ridge or on a hip, venting is not required.
3. Install Matterhorn® ridge cap with 2" screws directly over panel. Sealant may be needed in certain applications.

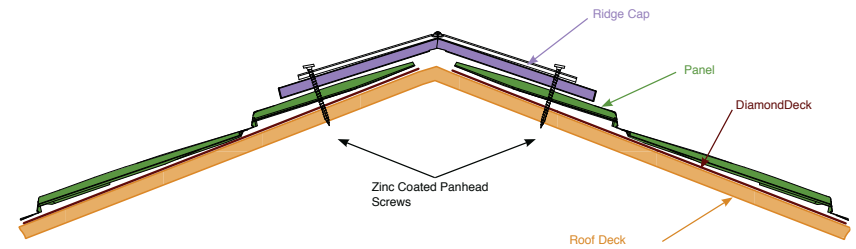

27

Watch detailed Matterhorn® Shake and Slate installation videos online at certainteed.com

Tools and Accessories

Required Tools

(Minimum recommend tools and equipment):

The standard set of tools and equipment in the general roofing trade.

Including: Cordless driver, snips, tape measure, electric metal saw, caulking gun, chalk line, hand seamer/hemming tool, gloves, square, felt tipped marker, needle nose pliers and a small flat head screw driver.



Cordless Driver



Tin Snaps



Chalk Line



Sheet Metal Gloves



Hand Seamer



Foam Pad

Special Additional Tools:

Not needed to complete the job but can improve install procedures and provide an overall finished look.



Sheet Metal Brake



Power Shears



Ladder Hook



Table Saw



Circular Saw

Accessories

(Most available through local roofing distributors):

Caulk: Butyl or urethane caulk/sealant

Tape: Butyl tape, or flashing tape on a roll, for side and end wall flashing

Boots: For vent pipes with metal sealer ring

Snow Guards: Should be placed as needed, and always refer to the manufacturing instruction guide when installing.

Refer to local distributor for more information.